

Production: Orlando				Loudspeaker List			
Director: Jen Wineman				Date: 12/08/09			
Sound Designer: Chad Raines							
Engineer/Assistant: Elizabeth Atkinson							
Spk #	Qlab #	Name	Type	Position	Focus	Patch point	
S1	1	HL Main	Meyer, UPA 1P	US of pros, off of gallery	6th row, 4th seat HR of C	Center Cat, mic input #	
S2	2	HR Main	Meyer, UPA 1P	US of pros, off of gallery	6th row, 4th seat HL of C	Center Cat, mic input #	
S3	1	HL Sub	EAW SB150	Gallery, by HL Main	Booth wall	Center Cat patch point #25	
S4	2	HR Sub	EAW SB150	Gallery, by HR Main	Booth wall	Center Cat patch point #26	
S5	3	Center Clus, L	Meyer, UPA 2P	Center, US of pros	Center pair, row 6	Center Cat, mic input #	
S6	4	Center Clus, R	Meyer, UPA 2P	Center, US of pros	Center pair, row 6	Center Cat, mic input #	
S7	5	Rear L	EAW JF200	Gallery, Booth/HR corner	House Center	FX/Mon #37 (Gallery, booth)	
S8	6	Rear R	EAW JF200	Gallery, Booth/HR corner	House Center	FX/Mon #41 (Gallery, booth)	
S9	7	HL Surr, US	EAW JF60	HL wall, below gallery, row 3	straight out from wall	FX/Mon #38 (split w/ S10) (Booth Cat)	
S10	7	HL Surr, DS	EAW JF60	HL wall, below gallery, row 3	straight out from wall	FX/Mon #38 (split w/ S9) (Booth Cat)	
S11	8	HR Surr, US	EAW JF60	HR wall, below gallery, row 3	straight out from wall	FX/Mon #42 (split w/ S12) (Booth Cat)	
S12	8	HR Surr, DS	EAW JF60	HR wall, below gallery, row 3	straight out from wall	FX/Mon #42 (split w/ S11) (Booth Cat)	
S13	9	Overhead, US, HL	EAW UB12	Booth Catwalk, low pipe, US side, 2'-6" HL of C	straight down	Booth Cat patch point, #21 (split w/ S14)	
S14	9	Overhead, DS, HL	EAW UB12	Booth Catwalk, low pipe, DS side, 9'-0" HL of C	straight down	Booth Cat patch point, #21 (split w/ S13)	
S15	10	Overhead, US, HR	EAW UB12	Booth Catwalk, low pipe, US side, 2'-6" HR of C	straight down	Booth Cat patch point, #22 (split w/ S16)	
S16	10	Overhead, DS, HR	EAW UB12	Booth Catwalk, low pipe, DS side, 9'-0" HR of C	straight down	Booth Cat patch point, #22 (split w/ S15)	
S17	11	Onstage, L	EAW JF200	Gallery, 3rd wing	straight OS, C	FX/Mon #39 (Shop Cat)	
S18	12	Onstage, R	EAW JF200	Gallery, 3rd wing	straight OS, C	FX/Mon #43 (Shop Cat)	
S19	13	UC	EAW FR153 (0:00 point)	Gallery, UC, on top of UC Sub	straight DS	South Up patch point #33	
S20	14	UC, Sub	Meyer USW	Gallery, UC	straight DS	South Up patch point #34	
S21	15	SR shop monitor	JFX100	Floor, shop	TBD	#13 or #40	
S22	16	SL shop monitor	JFX100	Floor, shop	TBD	#13 or #40	

LMS Matrix Patch		1	2	3	4	5	6	7	8
Soundweb In 01	1								
Soundweb In 02	2								
Soundweb In 03	3								
Soundweb In 04	4								
Soundweb In 05	5								
Soundweb In 06	6								
Soundweb In 07	7								
Soundweb In 08	8								

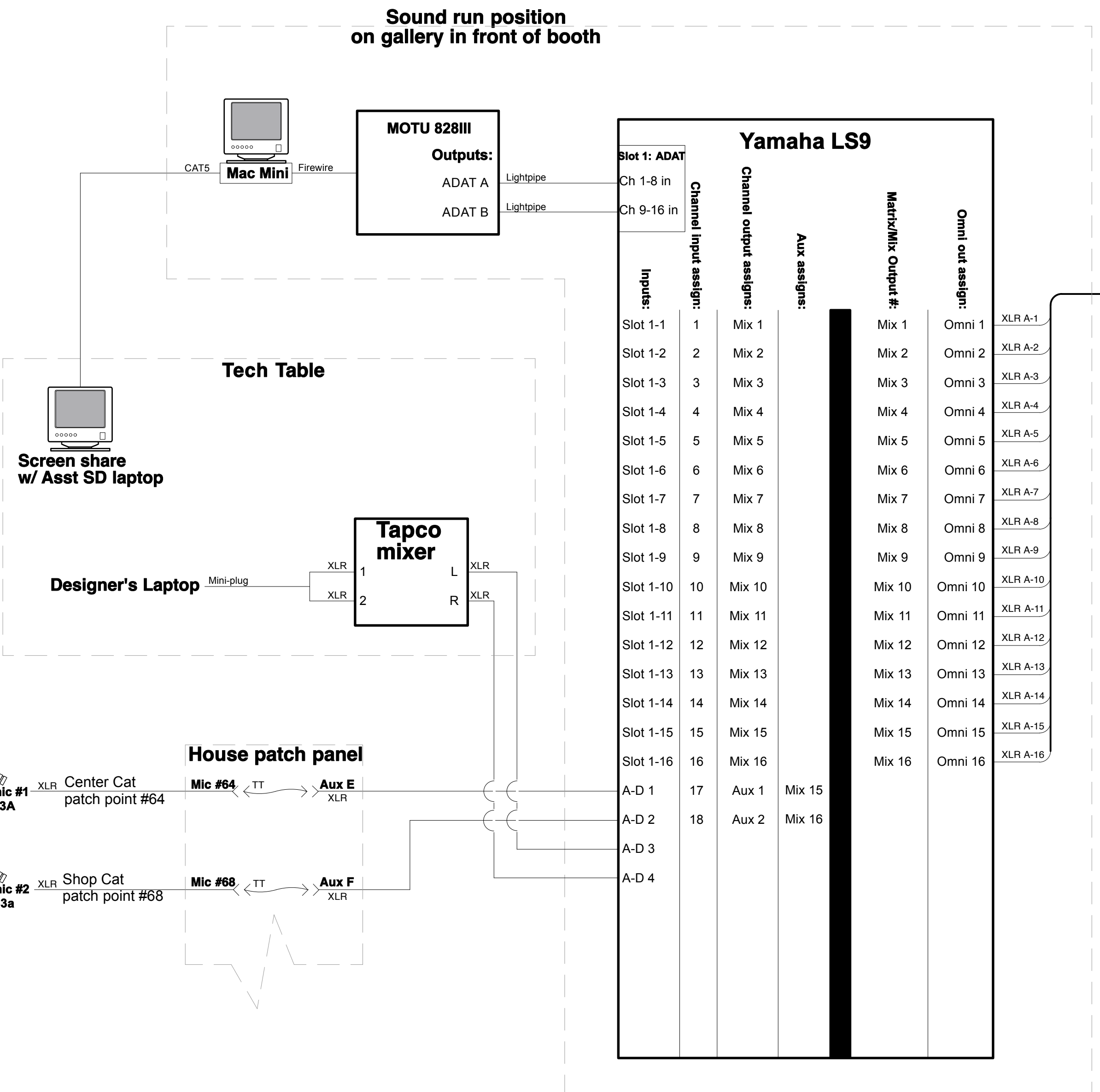

Please see supporting documentation for LMS configuration, hookup, additional processing & more!

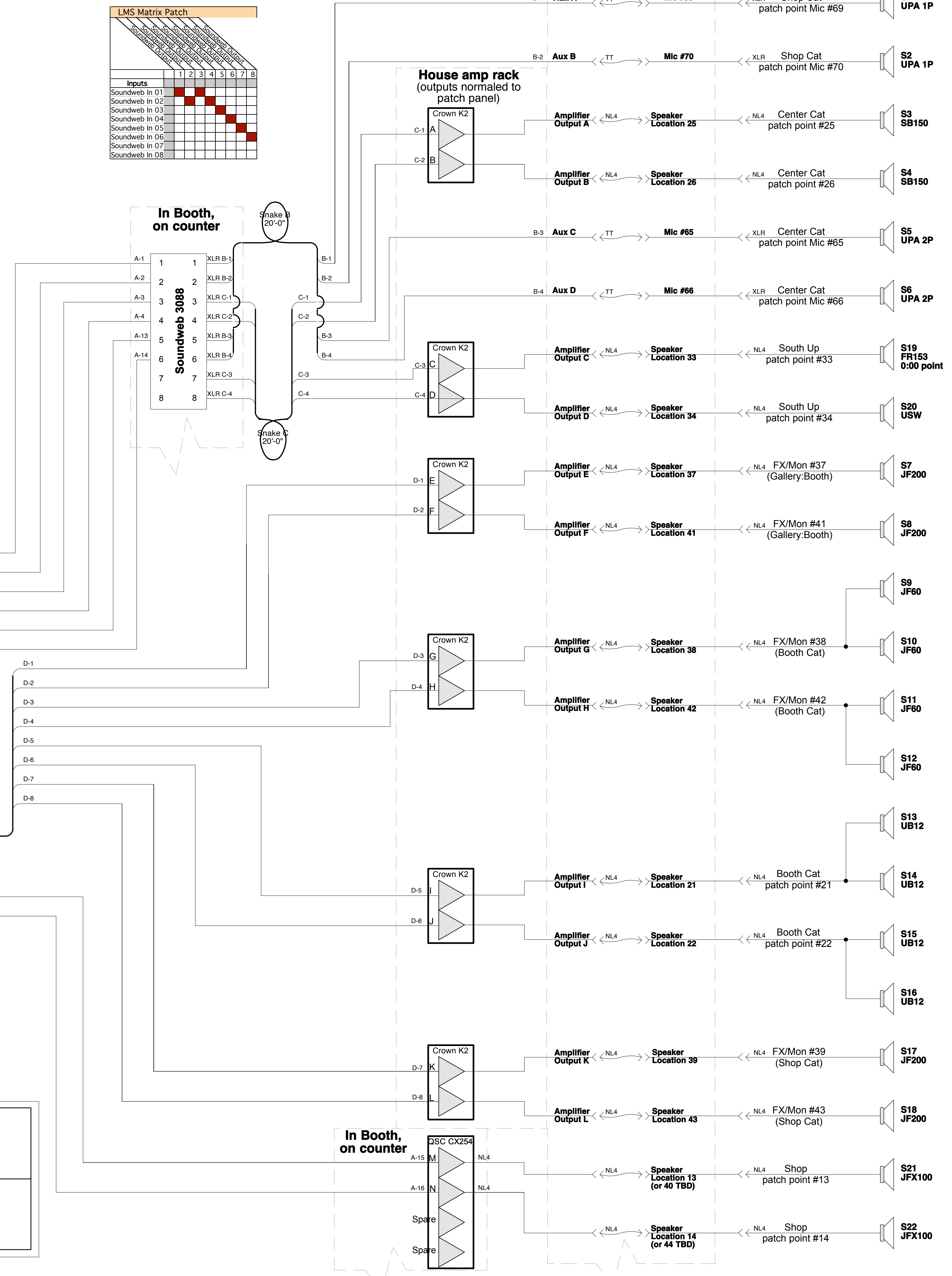

Date: 1/28/10	<b>Orlando</b> Yale School of Drama, Iseman Theatre	Sound Design: Chad Raines
Scale: N/A		Sound Engineer & drafting: Elizabeth Atkinson
Plate: 2 of 4		

Schematic Block Diagram